

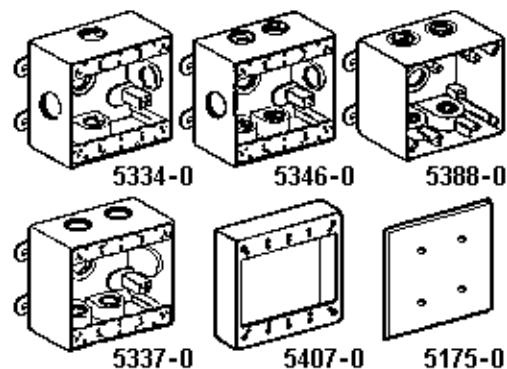

UL Listed - Standard 514A
CSA Certified - C22.2 No. 18

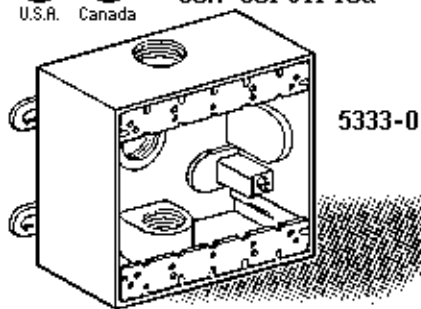

TWO-GANG ALUMINUM DEVICE BOXES

- For use in branch circuit wiring in wet, damp, or dry locations
- Can be used as a weatherproof junction box, or as housing for receptacles, switches and GFCI's

Seamless die cast aluminum construction, reinforced connector outlets, gray powder coat finish, two closure plugs -- and two mounting lugs (4 possible) included with each box, ground screw installed in box.
OPTIONAL -- Special threaded adaptors:

Cat.No. 5121135 1/2"NPT to PG13.5

Cat.No. 51212015 1/2"NPT to M20x1.5

Cat.No.	NPT Holes	Description	Dims. LxWxH (mm)	Wght/ea	UPE/Pack	EDP-No
5333-0	3 x 1/2"	Box with 2 MtgLugs	114.3x115.9x50.8	386g	12	101287
5334-0	5 x 1/2"	Box with 2 MtgLugs	114.3x115.9x50.8	369g	12	107136
5337-0	5 x 1/2"	Box with 2 MtgLugs	114.3x115.9x50.8	426g	12	107129
5346-0	7 x 3/4"	Box with 2 MtgLugs	114.3x115.9x50.8	381g	12	107141
5388-0	5 x 3/4"	Box with 2 MtgLugs	114.3x115.9x66.7	523g	9	105225
5303-0	---	2 Replacement Lugs	---	16g	100x2	101282
5175-0	---	Blank Cover/Gasket	114.3 x 115.9	110g	25	101236
5407-0	---	Extension Ring	114.3x115.9x25.4	176g	10	101319