



SPECIFICATIONS

Voltage ratings: AC: 600 Volts

DC: 480 Volts

Interrupting ratings: AC: 200,000 amperes rms symmetrical
300,000 amperes rms symmetrical
(Littelfuse self-certified).

DC: 20,000 amperes

Ampere range: 200 – 6000 amperes.

Approvals: AC: UL Listed Class L fuses per UL 248
(Formerly UL 198C)

(File No. E81895) — 601 – 6000 amperes

UL Recognized () (File No. E71611) —
200 – 600 amperes

CSA certified HRC-L (File No. LR29862)

QPL Federal Specification W-F-1814 —
700 – 6000 amperes

DC: Littelfuse self-certified

AMPERE RATINGS

200	500	800	1350	2000	3500
250	600	900	1400	2100	4000
300	601	1000	1500	2200	4500
350	650	1100	1600	2300	5000
400	700	1200	1800	2500	6000
450	750	1300	1900	3000	

Example part number (series & amperage): KLPC 1000

KLPC series POWR-PRO® fuses provide ideal overcurrent protection for circuits from 200 through 6000 amperes. KLPC series POWR-PRO® fuses specification-grade construction and performance meet or exceed the most stringent project specifications: 99.9% pure silver links, silver-plated copper end bells, glass-reinforced melamine bodies, O-ring seals between body and end bells, and granular quartz fillers.

KLPC series POWR-PRO® fuses are the only UL listed Class L fuses that provide a minimum of ten seconds time delay at 500% rated current and are also as current limiting as the fastest Class L fuse on the market. On average, the peak let-through currents of KLPC series fuses are 10% less than any other "time-delay" Class L fuse.

APPLICATIONS

Service switches

Switchboard mains and feeders

Bolted pressure contact switches

Motor control center mains

Large motor branch circuits

UL Listed series-rated protection for molded case circuit breaker panelboards and loadcenters. (See panelboard manufacturers' literature for recommended fuse rating.)

Primary and secondary protection for transformers

Protection of power circuit breakers

FEATURES AND BENEFITS

- **Eliminate unnecessary downtime** — KLPC POWR-PRO® series fuses' time delay withstands system surges and keeps your circuits in service.
- **Best protection for system components** — Maximum current limitation means less equipment and system damage when short circuits occur. Reduced damage means that electrical service can be restored quickly, reducing costly downtime, and often permitting equipment repair rather than replacement.
- **Coordinates with other system components** — KLPC series fuses provide maximum coordination with fuses and circuit breakers both on the line and load side of the fuses. See the Fuseology section of this catalog for additional information.
- **Eliminate need to oversize fuses** — This may permit the use of smaller less expensive switches, and, since the lower rated fuses are more current limiting, equipment receives even better protection.
- **300kA Interrupting Rating** — Littelfuse self-certified to 300,000 amperes as standard. Meets future trend towards higher available short circuit currents.

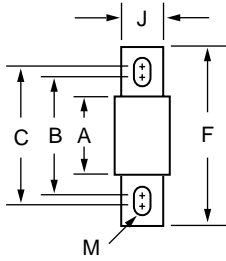

FIG. 1

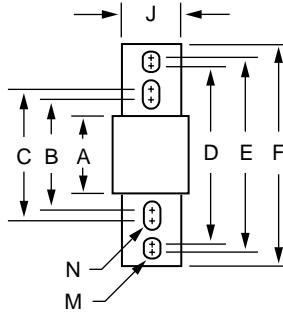

FIG. 2

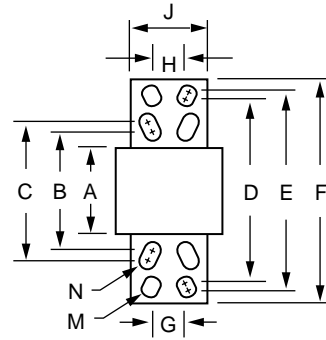

FIG. 3

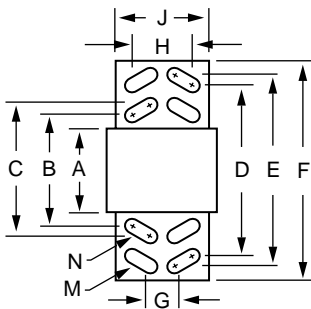

FIG. 4

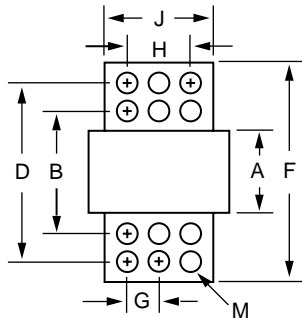
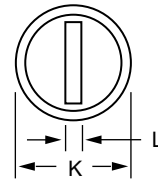

FIG. 5



AMPERES	FIG. NO.	DIMENSIONS IN INCHES (mm in parentheses)												
		A	B	C	D	E	F	G	H	J	K	L	M	N
200 – 800	1	3-3/4 (95.3)	5-3/4 (146.1)	6-3/4 (171.5)	—	—	8-5/8 (219.1)	—	—	2 (50.8)	2-1/2 (63.5)	3/8 (9.5)	5/8 x 1-1/8 (15.9) x (28.6)	—
801 – 1200	2	3-3/4 (95.3)	5-3/4 (146.1)	6-3/4 (171.5)	9-1/4 (235.0)	9-1/2 (241.3)	10-3/4 (273.1)	—	—	2 (50.8)	2-1/2 (63.5)	3/8 (9.5)	5/8 x 3/4 (15.9) X (19.1)	5/8 x 1- 1/8 (15.9) X (28.6)
1201 – 1600	2	3-3/4 (95.3)	5-3/4 (146.1)	6-3/4 (171.5)	9-1/4 (235.0)	9-1/2 (241.3)	10-3/4 (273.1)	—	—	2-3/8 (60.3)	3 (76.2)	7/16 (11.1)	5/8 X 3/4 (15.9) X (19.1)	5/8 X 1- 1/8 (15.9) X (28.6)
1601 – 2000	2	3-3/4 (95.3)	5-3/4 (146.1)	6-3/4 (171.5)	9-1/4 (235.0)	9-1/2 (241.3)	10-3/4 (273.1)	—	—	2-3/4 (69.9)	3-1/2 (88.9)	1/2 (12.7)	5/8 x 3/4 (15.9) x (19.1)	5/8 x 1- 1/8 (15.9) x (28.6)
2001 – 2500	3	4 (101.6)	5-3/4 (146.1)	6-3/4 (171.5)	9-1/4 (235.0)	9-1/2 (241.3)	10- 3/4 (273.1)	1-5/8 (41.3)	1-3/4 (44.5)	3-1/2 (88.9)	5 (127.0)	3/4 (19.1)	5/8 X 3/4 (15.9) x (19.1)	5/8 X 1- 1/8 (15.9) x (28.6)
2501 – 3000	3	4 (101.6)	5-3/4 (146.1)	6-3/4 (171.5)	9-1/4 (235.0)	9-1/2 (241.3)	10- 3/4 (273.1)	1-5/8 (41.3)	1-3/4 (44.5)	4 (101.6)	5 (127.0)	3/4 (19.1)	5/8 x 3/4 (15.9) x (19.1)	5/8 x 1- 1/8 (15.9) x (28.6)
3001 – 4000	4	4 (101.6)	5-3/4 (146.1)	6-3/4 (171.5)	9-1/4 (235.0)	9-1/2 (241.3)	10- 3/4 (273.1)	1-3/4 (44.5)	3-1/4 (82.6)	4-3/4 (120.7)	5-3/4 (146.1)	3/4 (19.1)	5/8 x 1-3/8 (15.9) x (34.9)	5/8 x 1-3/8 (15.9) x (34.9)
4001 – 5000	5	4 (101.6)	5-3/4 (146.1)	—	9-1/4 (235.0)	—	10-3/4 (273.1)	1-5/8 (41.3)	3-1/4 (82.6)	5-1/4 (133.4)	7-1/8 (181.0)	1 (25.4)	5/8 DIA. (15.9)	—
5001 – 6000	5	4 (101.6)	5-3/4 (146.1)	—	9-1/4 (235.0)	—	10-3/4 (273.1)	1-5/8 (41.3)	3-1/4 (82.6)	5-3/4 (146.1)	7-1/8 (181.0)	1 (25.4)	5/8 DIA. (15.9)	—

Current-Limiting Effects of KLPC (600V) fuses

* Prospective RMS Symmetrical Amperes Short-Circuit Current
 Note: Data derived from Peak Let-Thru Curves

Short Circuit Current*	Apparent RMS Symmetrical Current for various fuse ratings							
	800A	1200A	1600A	2000A	3000A	4000A	5000A	6000A
5,000	5,000	5,000	5,000	5,000	5,000	5,000	5,000	5,000
10,000	8,800	10,000	10,000	10,000	10,000	10,000	10,000	10,000
15,000	10,500	13,500	15,000	15,000	15,000	15,000	15,000	15,000
20,000	12,000	15,000	19,000	20,000	20,000	20,000	20,000	20,000
25,000	13,000	16,000	21,000	24,000	25,000	25,000	25,000	25,000
30,000	14,000	18,000	23,000	26,000	30,000	30,000	30,000	30,000
35,000	15,000	19,000	24,000	27,000	32,000	35,000	35,000	35,000
40,000	16,000	20,000	25,000	28,000	34,000	40,000	40,000	40,000
50,000	17,000	22,000	27,000	31,000	37,000	42,500	50,000	50,000
60,000	18,000	24,000	29,000	34,000	40,000	46,000	52,000	60,000
80,000	20,000	26,000	32,000	37,000	44,000	51,000	57,000	70,000
100,000	21,000	27,000	34,000	40,000	46,000	57,000	65,000	75,000
150,000	23,000	31,000	38,000	44,000	54,000	67,000	75,000	87,000
200,000	24,000	34,000	42,000	46,000	57,000	70,000	80,000	95,000

