

GFR SERIES

FAN FORCED HEATERS



APPLICATIONS

Fast heat response, contemporary design and quiet operation make GFR Series fan forced heaters ideal for bedrooms, dens, basements, converted attics, breezeways, garages, bathrooms, small offices, workshops, as well as larger or odd shaped rooms.

FEATURES

"CLIP 'N' FIT"®

US Patent No. 6,172,343

The NFR Series units all have "CLIP 'N' FIT"® feature which allows the installer to install heaters with lower wattages. With three models providing a wattage range from 375 watts to 2400 watts, the GFR Series are very versatile with a wattage selection to satisfy a wide range of applications.

Contemporary Styling

The heavy gauge steel front cover features beveled edges on the top and bottom to give the unit a pleasing, contemporary look.

MOUNTING LIMITATIONS

1. For wall mounting - Do not install back box closer than 4 inches from floor or 6 inches away from adjacent wall.
2. Do not install heater behind towel rack, behind door, in floor, in closet, in ceiling, or where air flow may be obstructed.

Over Temperature Protection

Each unit comes equipped with an automatic over temperature protector that guards against overheating. Also standard is a pilot light that indicates the protector has operated.

Uniform Heating Of All Discharge Air

Heavy gauge steel fins are brazed to low watt density steel sheathed tubular heating elements in a uniform grid pattern. The grid covers the entire discharge area, resulting in uniform heating of all discharge air, lower operating temperature and prolonged element life.

Quiet Operation

The tangential blower and the impedance protected, permanently lubricated motor provide trouble-free, whisper quiet operation.

Thermostat Options

The NFR Series units can be operated by either a built-in or wall mounted, single pole or double pole, line voltage thermostat. All three NFR models are available with or without a built-in double pole thermostat. Single and double pole, built-in thermostat kits are

also available for field installation.

Three Piece Construction

A separate back box, fan deck and front cover makes installation simple and quick. The slide in fan deck locks into place without the use of fasteners, cutting down on installation time.

Mounting Brackets

Two mounting brackets are provided with each unit to aid in installation into new construction. When utilized, they correctly position and level the back box in the stud wall. No need to use a tape measure or level — another feature to make installation faster.

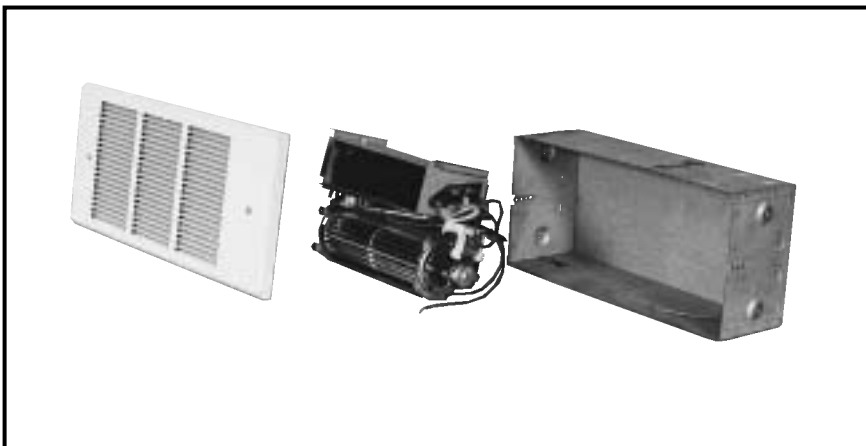

SELECTION CHART

CATALOG NUMBER	VOLTS (1Ø)	WATTS	AMPS	BUILT-IN THERMO.	WGHT. (LBS.)
GFR1500	120	1500	12.5	No	9
		1125	9.4		
		750	6.3		
		375	3.1		
GFR2004	240*	2000	8.3	No	9
		1500	6.3		
		1000	4.2		
		500	2.1		
GFR2404	240*	2400	10.0	No	9
		1200	5.0		
GFR1500T2	120	1500	12.5	Double Pole	9
		1125	9.4		
		750	6.3		
		375	3.1		
GFR2004T2	240*	2000	8.3	Double Pole	9
		1500	6.3		
		1000	4.2		
		500	2.1		
GFR2404T2	240*	2400	10.0	Double Pole	9
		1200	5.0		

*Will operate on 208V at 75% of rated wattages.

DIMENSIONS (IN INCHES)

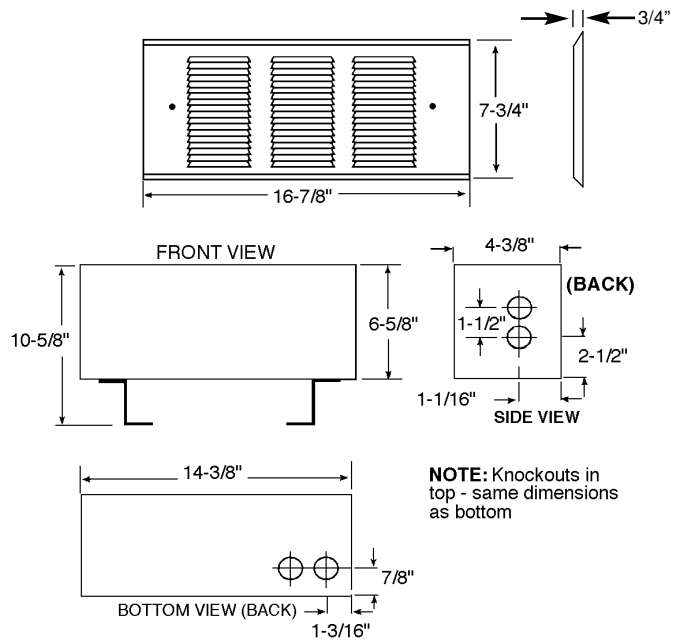

NOTE: Knockouts in top - same dimensions as bottom

ACCESSORIES

CATALOG NUMBER	DESCRIPTION	WEIGHT (LBS.)
GFRTPSP	Single Pole Built-In Thermostat; 25 AMPS @ 120-240V; 45° - 85°F Range	1
GFRDTP	Double Pole version of above	1
GFRSM	Surface Mounting Frame	2

ARCHITECT'S & ENGINEER'S SPECIFICATIONS*

The heating equipment shall include an electric automatic GFR Series fan-forced air heater suitable for small area heating

UL Listed and C-UL Listed. The heater shall be designed for recessed wall mounting.

BACK BOX: The back box shall be designed for duty as a recessed rough-in box in either masonry or frame construction. The back box shall be commercial grade galvanized steel and shall contain knock outs through which field wiring leads enter the box. A ground wire pigtail lead shall be attached to the back box. Detachable back box mounting brackets shall be used to insure proper installation.

INNER FRAME ASSEMBLY: The inner frame assembly shall consist of a commercial grade galvanized steel chassis on which are mounted the heating element, fan motor and tangential blower, and over temperature protector. The inner frame assembly shall be completely prewired with pigtail leads for field wiring. The inner frame assembly shall lock into the back box without fasteners.

HEATING ELEMENT: The heating element shall be guaranteed for five years and shall be of non-glowing design consisting of a 80/20 Ni-Ch resistance wire enclosed in a steel sheath to which steel plate fins are brazed. The element shall cover the entire air discharge area to ensure uniform heating of all discharge air. The wattage output of the unit shall be adjustable by moving jumper wires on a wattage control terminal board.

MOTOR AND CONTROLS: The fan motor shall be impedance protected and permanently lubricated. The thermostat shall be double pole on all models with factory installed thermostats. Optional single pole or double pole thermostat accessories shall be specified where the unit doesn't have a built-in thermostat. The over temperature protector shall be bi-metallic, snap-action type designed to shut off heater in the event of overheating. A pilot light shall be provided that will illuminate if the over temperature protector operates.

FRONT COVER: The louvered front cover shall be of commercial grade steel finished in Northern White enamel. It will attach to the back box with two screws.