

## Two-Stage General Purpose RFI Power Line Filter

### R Series

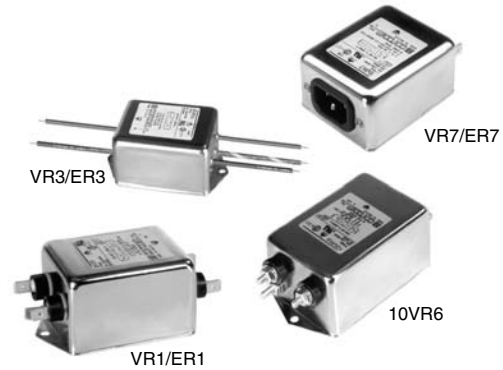

**UL Recognized  
CSA Certified  
VDE Approved**



### R Series

The dual T section RFI power line filters provide premium performance at moderate cost. They are well suited for low impedance loads where noisy RFI environments are present. They control pulsed, continuous and/or intermittent interference, providing protection to your equipment from power line noise in addition to protecting the line from equipment noise. The R series dual T type provides low leakage current without deterioration of insertion loss characteristics and at a competitive cost. The ER models meet the low leakage current requirements of VDE portable equipment, and (120 Volt) UL2601 non-patient medical equipment.

### Electrical Schematic

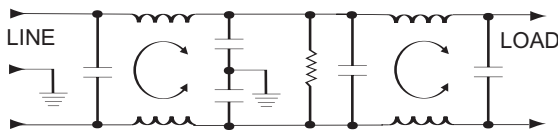

Resistor location for reference only.

### Case Style

#### 20VR6

Note: Same layout for 20VR1 and 20ER1, except .250 [6.35] (5) terminals replace Screw Terminals of 20VR6.

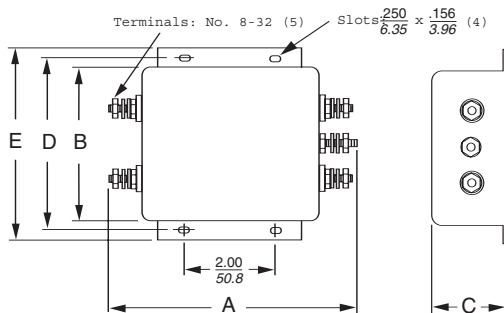

Torque 18 ± 2 in.lb

### Specifications

#### Maximum leakage current, each line-to-ground

	VR Models	ER Models
@ 120 VAC 60 Hz:	.4 mA	.21 mA
@ 250 VAC 50 Hz:	.7 mA	.36 mA

#### Hipot rating (one minute):

line-to-ground	2250 VDC
line-to-line	1450 VDC

#### Operating frequency:

50/60 Hz

#### Rated voltage (max.):

250 VAC

#### Minimum insertion loss in dB:

Line-to-ground in 50 ohm circuit

Current Rating	Frequency—MHz					
	.15	.5	1	5	10	30

#### VR Models

1A, 3A	30	65	65	65	65	65
2A, 5A, 10A, 20A	5	44	60	65	65	60

#### ER Models

1A, 3A	25	60	65	65	65	65
2A, 5A, 10A, 20A	2	35	51	63	60	50

Line-to-line in 50 ohm circuit

Current Rating	Frequency—MHz					
	.15	.5	1	5	10	30

#### VR, ER Models

1A, 3A	—	—	65	60	54	46
2A, 5A, 10A, 20A	—	—	35	60	57	45

## Two-Stage General Purpose RFI Power Line Filter (Continued)

### R Series

#### Case Styles

##### R1 (except 20 Amp)

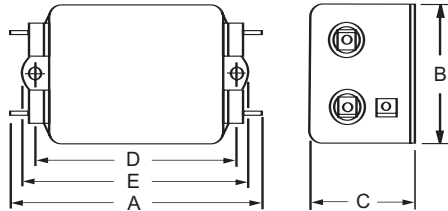

Typical dimensions:  
 Terminals: .250 [6.35] (5)      Holes: .07 [1.8] Dia.(4)  
 Mounting Holes: .188 [4.78] Dia. (2)      Slot: .07 x .16 [1.8 x 4.1]

##### R3

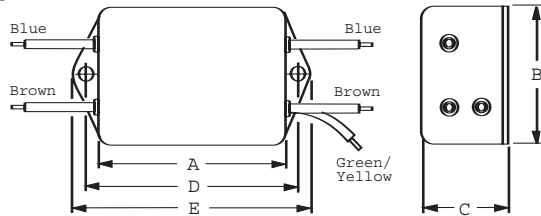

Typical dimensions:  
 Wire leads: 4.0 [101.6] Min.      Mounting Holes: .188 [4.78] Dia. (2)

##### 10VR6

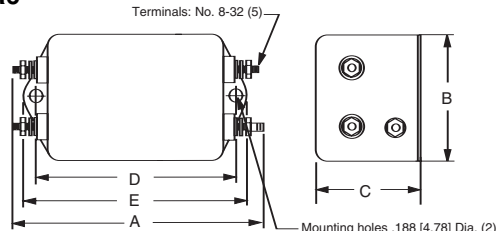

Torque: 18 ± 2 in.lb

##### R7 & R7M (with metric insert)

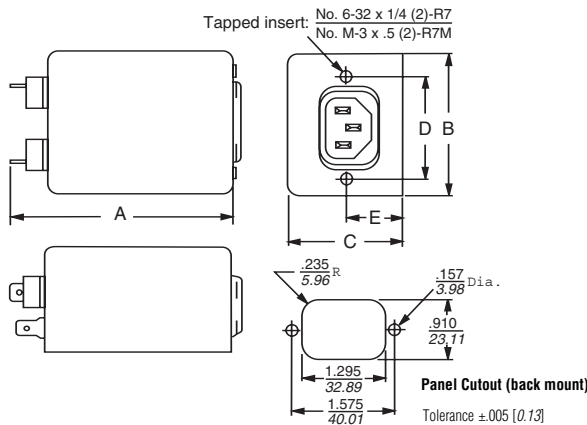

Typical dimensions:  
 Terminals: .250 [6.35] (5)      Holes: .07 [1.8] Dia.(4)  
 Mounting Holes: .188 [4.78] Dia. (2)      Slot: .07 x .16 [1.8 x 4.1]

#### Case Dimensions

Part No.	A (max)	B (max)	C (max)	D $\pm .015$ $\pm .38$	E (max)
1VR1, 1ER1,	3.35	1.81	1.16	2.375	2.78
2VR1, 2ER1	85.1	46.0	29.5	60.33	70.6
1VR3, 1ER3,	2.07	1.81	1.16	2.375	2.78
2VR3, 2ER3	52.6	46.0	29.5	60.33	70.6
3VR1, 3ER1,	3.85	2.07	1.16	2.938	3.35
5VR1, 5ER1	97.8	52.6	29.5	74.63	85.1
3VR3, 3ER3,	2.56	2.07	1.16	2.938	3.35
5VR3, 5ER3	65.0	52.6	29.5	74.63	85.1
3VR7, 3VR7M,	4.33	2.25	1.28	1.575	0.64
3ER7, 3ER7M	110.0	57.2	32.5	40.01	16.3 †
5VR7, 5VR7M,	4.33	2.25	1.28	1.575	0.64
5ER7, 5ER7M	110.0	57.2	32.5	40.01	16.3 †
10VR1, 10ER1	3.85	2.07	1.53	2.938	3.35
	97.8	52.6	38.9	74.63	85.1
10VR3, 10ER3	2.56	2.07	1.53	2.938	3.35
	65.0	52.6	38.9	74.63	85.1
10VR6	3.96	2.07	1.53	2.938	3.35
	100.6	52.6	38.9	74.63	85.1
10VR7, 10VR7M,	4.33	2.25	1.53	1.575	0.88
10ER7, 10ER7M	110.0	57.2	38.9	40.01	22.4 †
20VR1, 20ER1	5.23	3.37	1.53	3.75	4.20
20VR6	132.8	85.6	38.9	95.25	106.7

† ±.02 [±.5]

#### Part Numbers

1VR1	1ER1
1VR3	1ER3
2VR1	2ER1
2VR3	2ER3
3VR1	3ER1
3VR3	3ER3
3VR7	3ER7
3VR7M	3ER7M
5VR1	5ER1
5VR3	5ER3
5VR7	5ER7
5VR7M	5ER7M
10VR1	10ER1
10VR3	10ER3
10VR6	10ER7
10VR7	10ER7M
10VR7M	20ER1
20VR1	
20VR6	
Line Cord (R7/R7M):	GA400